



#MeasureIt

JAK ZDOKONALIT ...

Proces výroby válečkových ložisek



Úbytek profilu → Zkontrolujte a upravte brusný kotouč

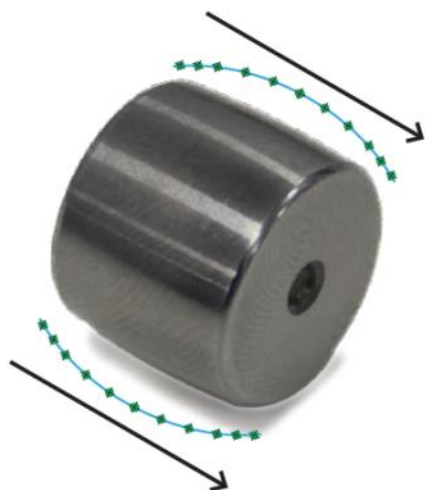

Válečkové ložisko - úbytek profilu

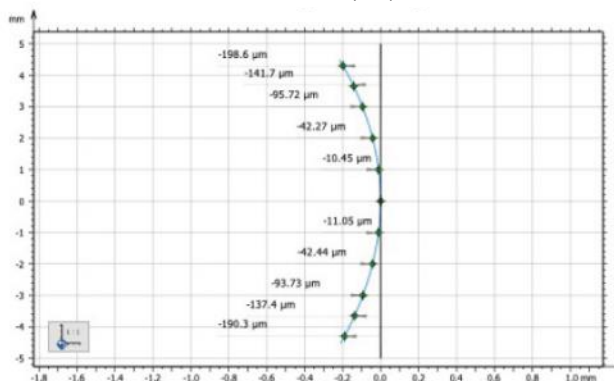

Measurement solutions
Form Talysurf® & Talyrond®



Chyba tvaru a tolerančních pásem → Zkontrolujte a upravte brusný kotouč

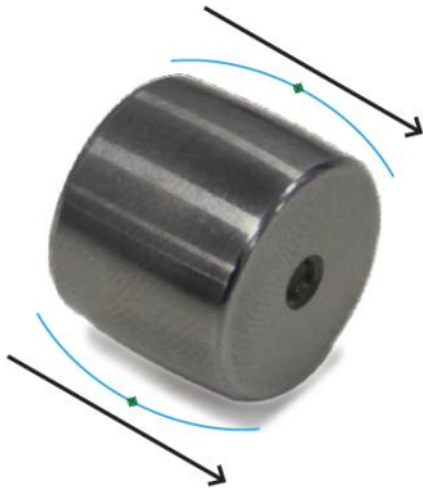

Válečkové ložisko - profil s tolerančními pásmy a chybou tvaru (Pt)

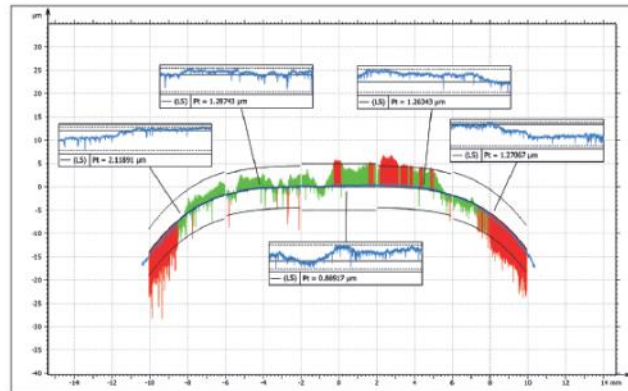

Measurement solutions
Form Talysurf® & Talyrond®



Kompensace osy X vůči čelům válečku → Pokud je potřeba, upravte osu nástroje

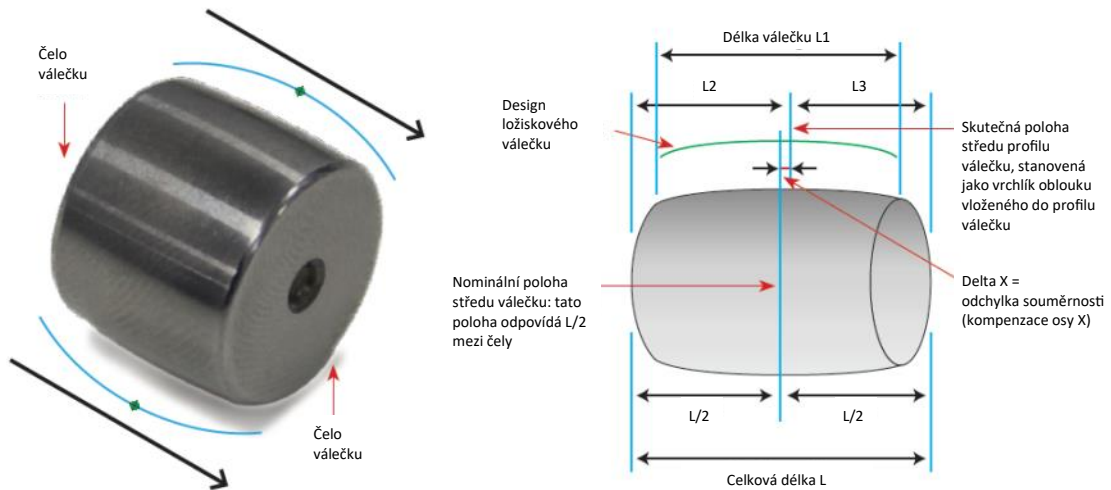

Measurement solutions
Form Talysurf® & Talyrond®



Naklonění profilu vůči ose válečku → Nastavte úhel brusného kotouče



Relativní
náklon profilu
k ose válečku

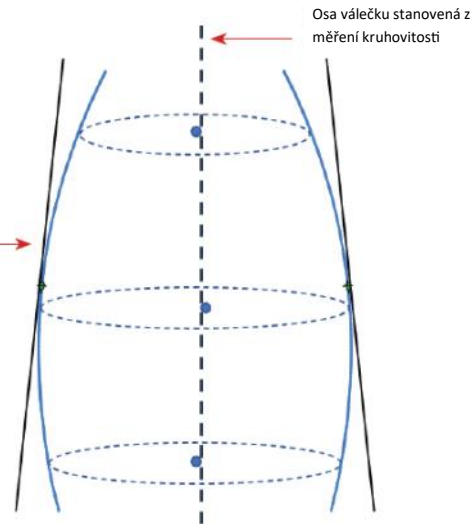

Measurement solution
Talyrond®

