

FORM TALYSURF® PGI OPTICS PRO

System specification

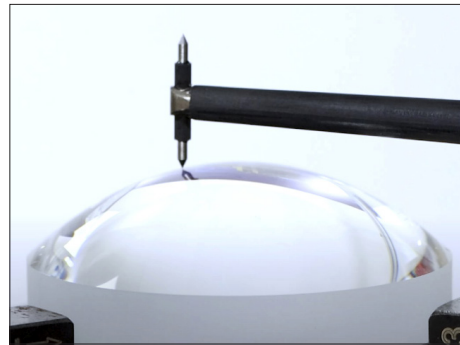
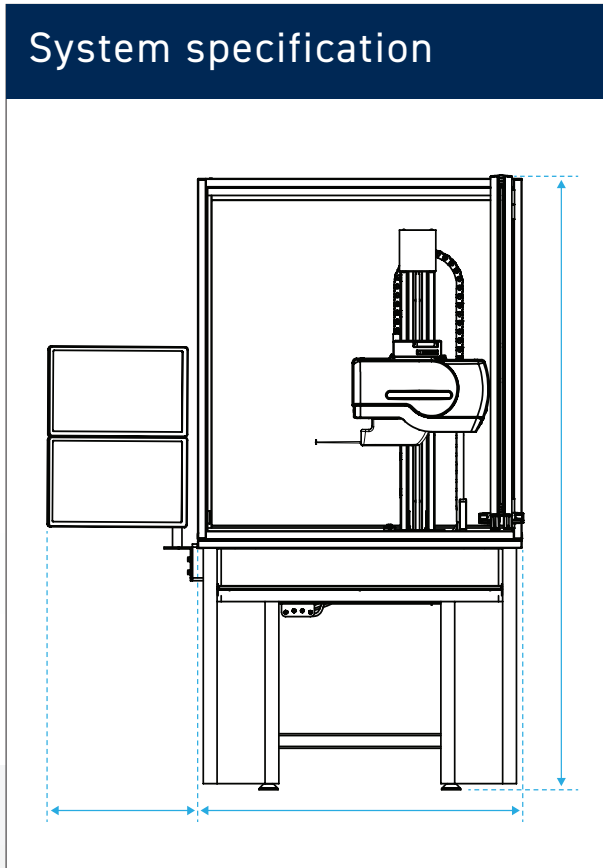

System specification

System performance ¹	10 mm Gauge	15 mm Gauge	20 mm Gauge
Nominal measuring range (Z) ³	10 mm (0.39 in)	15 mm (0.59 in)	20 mm (0.79 in)
Range to resolution ³	50,000,000 : 1	75,000,000 : 1	104,000,000 : 1

System performance ¹ (All variants)		Horizontal performance	
System noise ²	Rq < 2 nm (0.08 µin), Rz < 10 nm (0.39 µin)	Traverse length – X Max. / Min.	120 mm / 0.1 mm (4.7 in / 0.004 in) 200 mm / 0.1 mm (7.9 in / 0.004 in) 300 mm / 0.1 mm (11.8 in / 0.004 in)
System noise with extension tube ²	Rq < 6 nm (0.24 µin) Rz < 30 nm (1.18 µin)	Traverse speeds	13 mm/s Max. (0.51 in/s)
Form uncertainty (Pt) ⁴	< 100 nm (4 µin) typically ~60 nm (2.4 µin)	Measuring speed ⁵	0.1 mm/s, 0.2 mm/s, 0.5 mm/s, 1 mm/s, 2 mm/s & 5 mm/s (0.004 in/s, 0.008 in/s, 0.02 in/s, 0.04 in/s, 0.08 in/s & 0.2 in/s)
Radius measurement uncertainty ⁷	0.1 mm - 10 mm (0.004 in - 0.39 in)	10 mm - 360 mm (0.39 in - 14.17 in)	Minimum data sampling interval in X
	± 1 µm (39.4 µin)	± (0.41 + R [mm] / 17) µm; (± (16.14 + 58.8 R [in]) µin)	25 nm (0.98 µin)
3D Raster Calibration (St)	< 500 nm (20 µin) typically ~350 nm (12 µin)		Straightness uncertainty (Pt) ⁶
Measuring station		Y-axis length – Y Max. / Min.	120 mm Traverse unit - 0.08 µm (3.2 µin) 200 mm Traverse unit - 0.110 µm (4.3 µin) 300 mm Traverse unit - 0.150 µm (5.9 µin)
Instrument dimensions	See floor plan (Page 3)		Y-axis positioning speeds
Instrument weight ¹⁰	420 kg		0.1 mm/s to 18 mm/s (0.004 in/s to 0.7 in/s)
Motorized vertical column	450mm (17.7 in) / 700 mm* (29.5 in)		Vertical performance
Maximum component weight for motorized stages	6.8 kg		Resolution (Z) ³
Rotary axis		Z axis positioning speeds	0.2 nm (0.01 µin)
Positional accuracy	0.078 deg		Measurement Direction
Positioning speeds	0.1 deg/s to 35 deg/s		Single / Bi-directional*
Environment		Z distance measurement uncertainty ⁹	0.1 mm/s to 80 mm/s
Operating temperature (recommended)	18 °C to 22 °C (64 °F to 72 °F)		Z distance measurement uncertainty ⁹
Temperature gradient	< 2 °C per hour (< 3.6 °F per hour)		± (1.0 + L [mm] / 150) µm; ± (39.4 + 6.67 L [in]) µin
Operating humidity	45% to 75% relative, non condensing		Linearity uncertainty ⁸
Maximum RMS floor vibration	3 µm/s (120 µin/s) at < 50 Hz 6 µm/s (200 µin/s) at > 50 Hz		0.05 + 0.02 Z [mm] µm (2 + 20 Z [in] µin)
Laser classification		Stylus arm length	Standard length - 100 mm
Class 1 Laser product to EN 60825-1:2014. Compliant with 21CFR 1040.10 and 1040.11 of the United States FDA (except for deviations pursuant to Laser Notice 50, dated June 24, 2007)		Tip size	60° 2 µm radius conisphere diamond
		Force (software controlled)	30 mgf - 225 mgf
		Electrical (alternating supply, single phase with earth, 3-wire)	
		Instrument and computer voltage	Standard 100V to 230V Active AV 115 V to 230V
		Frequency	47 Hz to 63 Hz
		Power consumption	1000 VA (Inc. PC, etc.)

CE Low Voltage Directive 2014/35/EU, EMC Directive 2014/30/EU, Machinery Directive 2006/42/EC, RoHS Directive 2011/65/EU

Compliance to directives is demonstrated using applicable European standards and sections therein.

Qualifiers

- Measured using 100 mm, 2 µm, 60° Diamond stylus.
- Measured over a glass flat nominally parallel to the traverse datum using a 100 mm diamond stylus (speed = 0.5 mm/s, Gaussian roughness filter, Lc 0.08 mm, Ls 0.0025 mm).
- Using a 100 mm diamond stylus.
- From a repeat measurement on 22 mm calibration artifact over 7 mm of the gauge range (LS Arc analysis, primary filter λs = 0.25 mm).
- For surface texture measurements, speeds of 0.5 mm/s (0.02 in/s) and less are recommended.
- Measured over a glass flat nominally parallel to the traverse datum (speed = 1 mm/s, LS Line analysis, primary filter Ls = 2.5 mm). Does not take in to account the form error of the calibrated glass flat artefact.
- Assumes a calibration artefact of perfect radius.
- Measurements up and down a ±35° angled slope over 80% of the gauge range using a 100 mm diamond stylus.
- Valid for high precision steel column only. Measured using recessed styli. Artefact corrected to 20°C.
- System includes 200 mm traverse unit, high-precision column, instrument surround and environmental chamber.

Notes

All relevant specifications apply to measurements taken in both biases.
The above quoted technical data is for measurements taken in a metrology laboratory controlled environment: 20°C ±1°C (68°F ± 1.8°F), draft free and isolated from low frequency floor borne vibration.
The above specification has been derived at 75 mgf.
All uncertainties are at 95% confidence in accordance with recommendation in the ISO guide to the expression of uncertainty in measurement (GUM:1993).

System floor plan

Modular design

- Environmental chamber
- Surround with shelf
- Two display monitors attached to surround

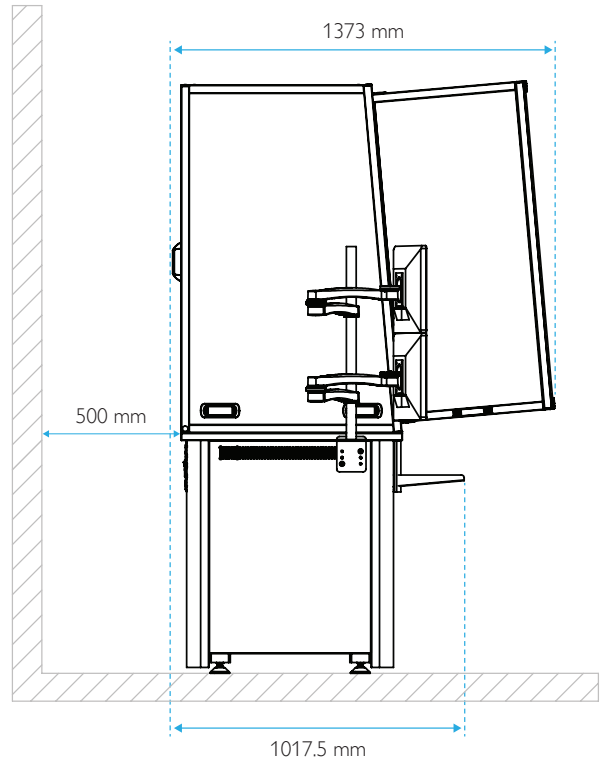
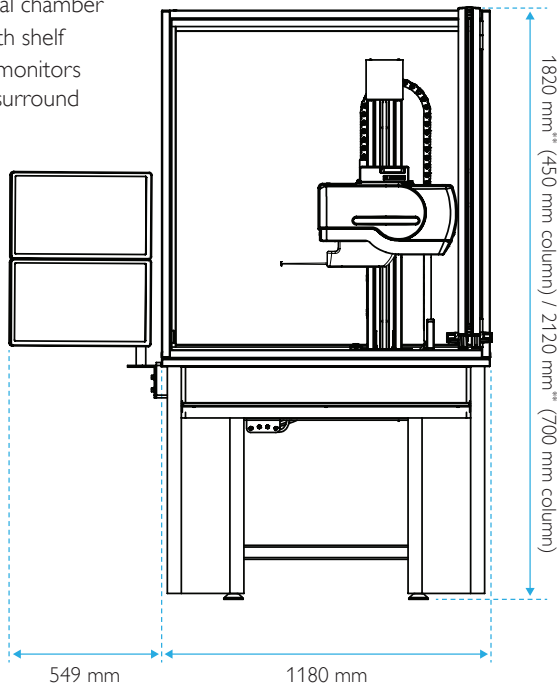

Modular design

- Single display monitor on a separate desk

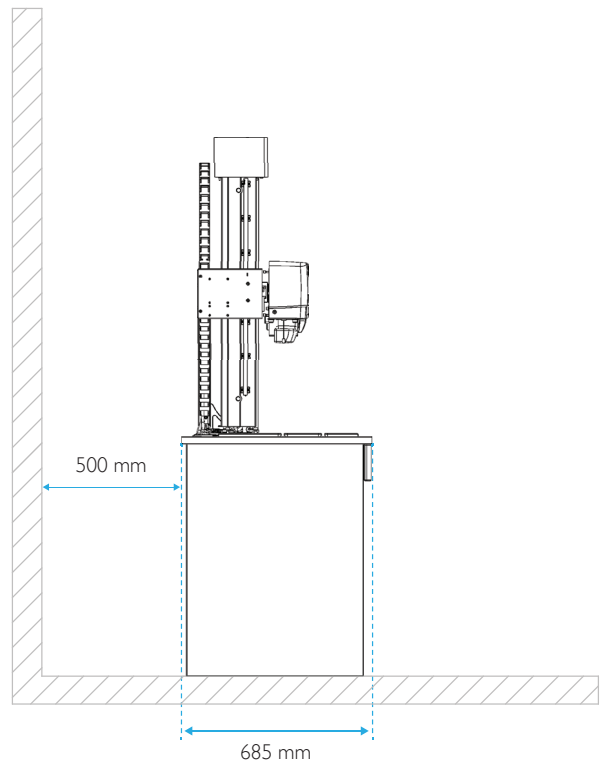
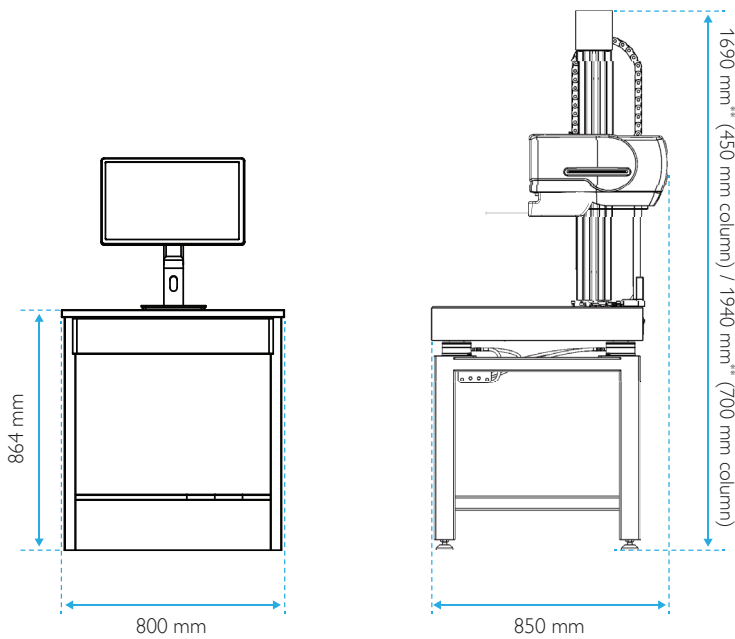

System floor plans are a visual representation and may differ slightly. System floor plan displayed for Form Talysurf® PGI OPTICS PRO with surround only. Taylor Hobson pursues a policy of continual improvements due to technical developments. We therefore reserve the right to deviate from catalogue specifications.

* Optional.

** Add 80 mm for system with Active AV.

Sales

Email: taylor-hobson.sales@ametech.com
 Tel: +44 (0) 116 276 3771

- **Design Engineering** – Special purpose and dedicated metrology systems for demanding applications.
- **Precision Manufacturing** – Contract machining services for high precision applications and industries.

Service

Email: taylor-hobson.service@ametech.com
 Tel: +44 (0) 116 246 2900

- **Preventative Maintenance** – Protect your metrology investment with an AMECare support agreement.
- **Upgrades** – Carried out by Taylor Hobson accredited service engineers and include installation and calibration to ensure your system runs at peak performance.

Metrology Support

Email: taylor-hobson.cofe@ametech.com
 Tel: +44 (0) 116 276 3779

- **Contract Measurement** – A cost effective option to capital expenditure, simply send in first article or production components for measurement.
 Measurement of your parts is carried out by skilled technicians using industry leading instruments in accord with ISO standards.
- **Metrology Training** – Practical, hands-on training courses for roundness and surface finish conducted by experienced metrologists.
- **Operator Training** – On-site instruction will lead to greater proficiency and higher productivity.
- **UKAS Calibration & Testing** – Certification for artifacts or instruments in our laboratory or at customer's site.



0026



2624

© Taylor Hobson Ltd.

World-Class Global Support

www.taylor-hobson.com



Taylor Hobson UK

Tel: +44 (0)116 276 3771
taylor-hobson.sales@ametech.com



Taylor Hobson France

Tel: +33 130 68 89 30
taylor-hobson.france@ametech.com



Taylor Hobson Germany

Tel: +49 6150 543 0
taylor-hobson.germany@ametech.com



Taylor Hobson Italy

Tel: +39 02 946 93401
taylor-hobson.italy@ametech.com



Taylor Hobson India

Tel: +91 80 6782 3346
taylor-hobson.india@ametech.com



Taylor Hobson China

taylor-hobson-china.sales@ametech.com

Shanghai Office

Tel: +86 21 5868 5111-110

Beijing Office

Tel: +86 10 8526 2111

Guangzhou Office

Tel: +86 20 8363 4768



Taylor Hobson Japan

Tel: +81 34400 2400
taylor-hobson.japan@ametech.com



Taylor Hobson Korea

Tel: +82 31 888 5225
taylor-hobson.korea@ametech.com



Taylor Hobson Singapore

Tel: +65 6484 2388
taylor-hobson.singapore@ametech.com



Taylor Hobson Thailand

Tel: +66 2 012 7500
taylor-hobson.thailand@ametech.com



Taylor Hobson Taiwan

Tel: +886 3 575 0099 Ext 301
taylor-hobson.taiwan@ametech.com



Taylor Hobson Mexico

Tel: +52 442 426 4480
taylor-hobson.mexico@ametech.com



Taylor Hobson USA

Tel: +1 630 621 3099
taylor-hobson.usa@ametech.com